

### Heavy-Duty Structure

1150mm or 1220mm length for selection  
 540mm or 680mm width for selection  
 PU castors and wheels  
 Big capacity up to 3000kg  
 Heavy structure design



### M28 | H8C LoadCell

Default with M28 load cells  
 IP67 protection, Alloy steel material  
 -optional OIML/NTEP approved H8C load cells

### K7A Indicator

Big backlit FSTN LCD display  
 - the weight can be read clearly even in the sun.  
 With rechargeable 6V4Ah battery  
 100-240v power source directly  
 kg/lb, g/oz units exchange  
 Real-time clock, time/date display  
 Checkweigh with three LED lights  
 Animal weighing function, accumulating, hold  
 x10 accuracy, counting, zero, tare, printing, etc.  
 Default with 2 RS232 interface  
 Option of Bluetooth or WiFi output  
 Optional printer - **154001 PH-PRT**  
 Optional OIML/EC Type approved indicator

### Dimension

<b>Platform Sizes</b> 1150 x 540mm 1220 x 680mm	<b>Power</b> 100-240V 50/60Hz Battery: 6V5Ah
<b>Capacity</b> 2000kg 3000kg - optional	<b>Display</b> FSTN LCD - 37mm
<b>Display Resolution</b> 0.5kg   1.0kg	<b>Units</b> Kg/lb g/oz
<b>Load Cell</b> M28   H8C	<b>Output</b> RS232 * 2
<b>Load Cell Protection</b> IP67	<b>Operating Temperature</b> -10°C - 40°C

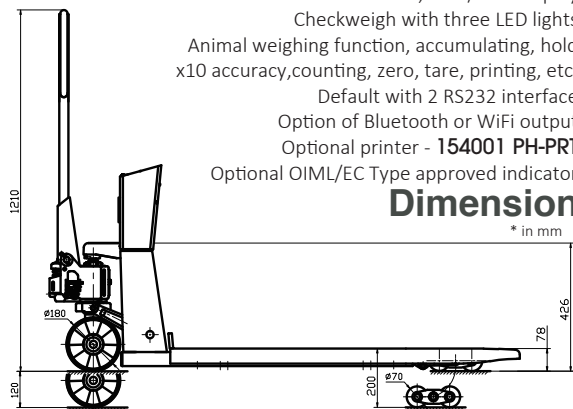
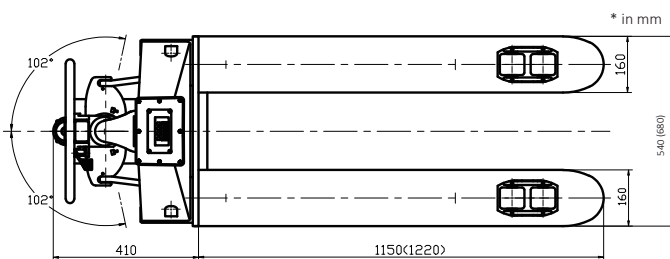

### Models \*2500kg | 3000kg capacity optional

Part No.	100708	100709	154001
Models	PHA	PHA680	PH-PRT
<b>U.P.(USD)</b>	<b>\$1,780.00</b>	<b>\$1,860.00</b>	<b>\$340.00</b>
Capacity	2000kg	2000kg	-
Division	0.5kg	0.5kg	-
Weight	120kg	120kg	-